

CDP301

Condumax Dew-Point Tester

Manual hydrocarbon and water dew-point tester for natural gas.



Highlights

- Fundamental cooled-/chilled-mirror dew-point measurement principle
- High-definition color LC display
- Visual identification of both water and hydrocarbon dew point
- Automatic mirror cooling rate control according to ISO 6327 and ASTM D1142 test methods for natural-gas dew-point measurements
- Self-contained, rechargeable battery powered
- Exd certified IECEx ATEX, UKCA Zone 1, Class I Division 1/Zone 1, IIB+H2 T3
- 100 barg (1450 psig) operating pressure rating
- Greater than 60 °C (140 °F) measurement depression range (up to 100 barg/1450 psig pressure)
- Better than ± 0.5 °C (± 0.9 °F) accuracy of mirror surface measurement

Applications

- Natural Gas Processing
- Transmission Pipeline Checking
- Sour Natural Gas
- Validation of online analyzers



Hydrocarbon Dew Point: A Critical Natural Gas Quality Parameter

For natural gas producers, pipeline operators, and direct contract buyers, hydrocarbon dew point is difficult to measure and control. It is vital to avoid custody transfer disputes, which can result in shut-ins due to today's tighter contractual limits.

Since 1986, the direct chilled mirror technique incorporated in the Michell Instruments Condumax II is the definitive method of measuring hydrocarbon dew point, and is preferred by most gas producers, pipeline operators, and direct contract buyers around the world.

Introducing the CDP301 Dew-Point Tester

The CDP301 dew-point tester extends this capability, adding portability and the latest features and specifications to a proven measurement technique and offers the user a 21st-Century advancement of the Bureau of Mines Dew Point Tester. The CDP301 is a manual, visual dew-point tester for natural gas processing and transmission applications. It is fully self-contained within a lightweight alloy explosion-proof enclosure, easy to hand carry by a single person, and is powered solely by the internal rechargeable battery.

Measure, Capture, Review

An integral high-definition camera allows the capture of timestamped still and video imaging of the mirror surface. Via a highly intuitive interface, the user observes the formation of condensation on the cooled-mirror surface. During each measurement cycle the instrument provides a clear image of the mirror surface which, in combination with optimized optical illumination techniques, enables the operator to distinguish between water and HC precipitation to perform both dew-point measurements. With a push of a button the operator captures the mirror image and logs the temperature and pressure at which a sufficient layer of frost/condensation occurred.

Mirror cooling is achieved by a thermoelectric heat-pump under the control of the operator aided by the instrument's firmware. Cooling rate is precisely controlled to enable sensitive detection and repeatable measurements in accordance with the relevant ASTM and ISO test methods specific to dew point in natural gas.

Mirror images (both stills and videos) with corresponding data for multiple measurement cycles can be stored for later review,

either using the instrument's HMI color display or by transfer via USB to the customer's PC*.

This technology is incorporated into a field portable device, with up to 8 hours' battery life and with the ability to swap in a spare battery if required*.

A full range of options is available to ensure the instrument can be easily transported and set up at site, ready to use in minutes.

*Data transfer and charging or replacement of the batteries MUST be carried out in a safe area

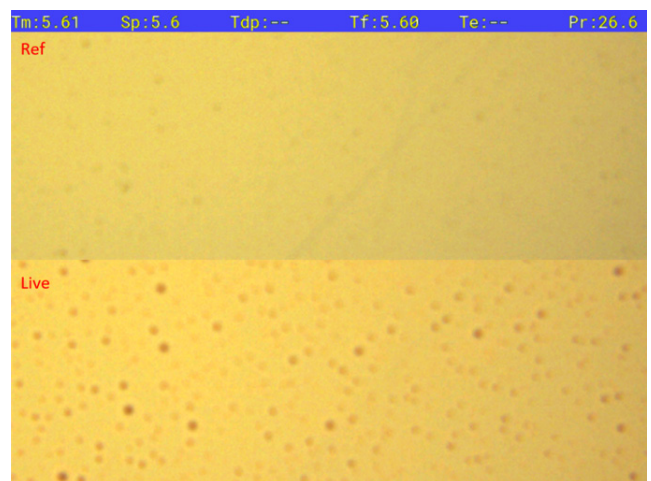

Displayed image in HCDP mode (Split Screen)

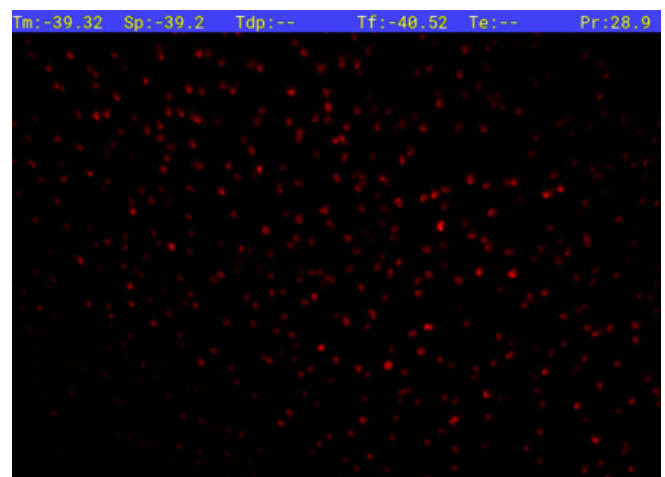

Displayed image in WDP mode

CDP301 Accessories

Fully portable measurement, ready to use in minutes

The CDP301 is housed in a cast aluminum alloy Exd enclosure suitable for 5/8" - 11 UNC tripod mounting and bench-top operation, using the optional Michell Instruments bench-top stand. The Tester is a battery-powered field-portable device, with up to 8 hours' battery life and with the ability to swap in a spare battery if required*. A full range of options is available to ensure the instrument can be easily transported and set up at site, ready to use in minutes.

*Charging and replacement of the batteries MUST be carried out in a safe area.



Purpose-designed sample system

Our CDP301 sample system facilitates regulation of pressure and flow, and the removal of contaminants, delivering a properly conditioned sample to the Tester for reliable measurements, and trouble-free operation. The optional sample system is constructed from 316 stainless steel components, and flexible stainless steel connection hoses are also available.



Fully hazardous-area capable

The Dew-Point Tester is designed to be positioned close to the process sample test point and is ATEX, IECEx, UKCA or cQPSus compliant for use in a Zone 1 or 2 Hazardous Area and Class I, Div 1 Hazardous Locations.

The custom-designed rucksack is produced using static dissipative materials allowing all required accessories to be easily carried into the working area.



Fully transportable

The CDP301 is supplied with both a rucksack and a wheeled hardcase which can carry all the required accessories including the sample system, mains charger, spare battery and mirror cleaning kit. The hardcase provides safe and secure storage and can be used for road and air transport.



Technical Specifications

Hydrocarbon & Water Dew-Point Measurement	
Measuring technique	Chilled mirror
Sensor cooling	Automated cooling ramp rate selectable according to ASTM D1142 or ISO6327 measurement practice
Maximum range	Depression range up to $\Delta T > 65\text{ }^\circ\text{C}$ (149 $^\circ\text{F}$)
Accuracy	$\pm 0.5\text{ }^\circ\text{C}$ ($\pm 0.9\text{ }^\circ\text{F}$)
Resolution	0.1 $^\circ\text{C}$, 0.1 $^\circ\text{F}$
Sample flow	0.25...0.5 NL/min
Pressure Measurements HCDP & WDP	
Units	MPa, barg, psig
Resolution	0.1 MPa, 0.1 barg, 1 psig
Accuracy	$\pm 0.25\%$ FS
Dew-Point Tester	
Operating pressure	Up to 100 barg (1450 psig)
Sample supply pressure	20...100 barg (290...1450 psig)
Enclosure	Cast LM25 Alloy IP64/NEMA4X
Gas connections	1/4" NPT
Operating environment	-30 $^\circ\text{C}$...+50 $^\circ\text{C}$ (-22 $^\circ\text{F}$...+122 $^\circ\text{F}$) max 95%rh
Power supply	Rechargeable Li-ion battery, up to 8 hours' life from full charge
Weight	8 kg (17.6 lb)
Display & user interface	High-definition 5.7" full-color display, operated by 5 push buttons
Logging/Image capture	2GB onboard data storage
Hazardous area certification	ATEX/UKCA: II 2 G Ex db ia IIB+H2 T3 Gb (Tamb -30 $^\circ\text{C}$...+50 $^\circ\text{C}$)
	IECEX: Ex db ia IIB+H2 T3 Gb (Tamb -30 $^\circ\text{C}$...+50 $^\circ\text{C}$)
	cQPSus: Class I, Division 1, Gr BCD T3 (Tamb -25 $^\circ\text{C}$...+50 $^\circ\text{C}$) Class I, Zone 1 AEx db ia IIB+H2 T3 Gb (Tamb -30 $^\circ\text{C}$...+50 $^\circ\text{C}$) Ex db ia IIB+H2 T3 Gb (Tamb -30 $^\circ\text{C}$...+50 $^\circ\text{C}$)
Data transfer	USB Standard B connector for log/image transfer (safe area only)
Mounting	5/8 inch 11 UNC thread suitable for Tripod mount. Optional bench top mount.

Product Dimensions

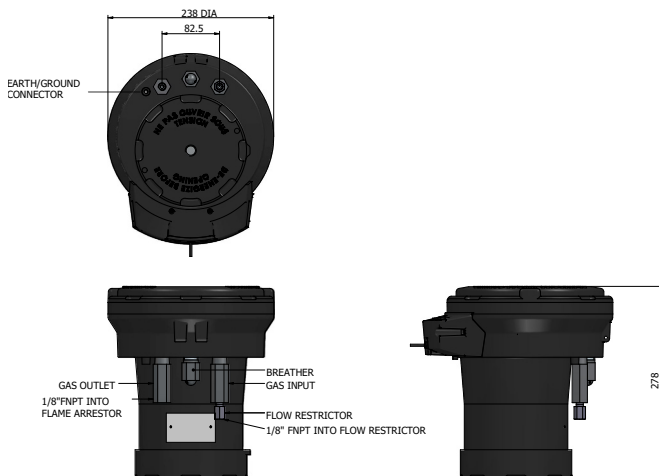

Related Process Products



Condumax II
Hydrocarbon Dew-Point Analyzer



Condumax II Transportable
Hydrocarbon & Water Dew-Point Analyzer

Rotronic Instruments Corp. 135 Engineers Road, Suite 150, Hauppauge NY 11788
Tel: 631 427 3898, Email: us.info@michell.com, Web: www.michell.com/us

Michell Instruments adopts a continuous development programme which sometimes necessitates specification changes without notice.
Issue no: CDP301_99994_V2.2_US_Datasheet_0821